

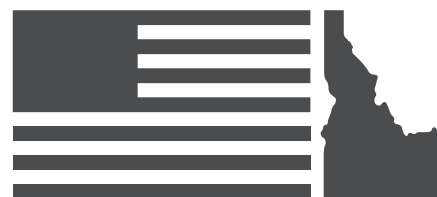

**TACTICAL SOLUTIONS
INSTRUCTION MANUAL
FOR THE
AR-22 BOLT & BARREL COMBO**

2772 SOUTH VICTORY VIEW WAY
BOISE, IDAHO 83709
866.333.9901

VISIT US ONLINE AT:
WWW.TACTICALSOL.COM



PROUDLY MADE IN BOISE, ID

1

TACTICAL SOLUTIONS AR-22 BOLT & BARREL COMBO

Thank you for buying a Tactical Solutions product. Please read the full owner's manual before use.

The following instructions are designed to help you through the process of installation, disassembly, cleaning, lubrication and reassembly of your AR-22 Bolt & Barrel Combo. The AR-22 Combo assembly is compatible with any standard AR-15 upper receiver. This Combo is designed to operate with "military spec" AR-15 triggers. Aftermarket triggers may or may not impact the performance of this conversion upper.

LOADED WEAPON WARNING

Always make sure your gun is unloaded before any work is started. Never clean, lubricate, disassemble, reassemble or work on any firearm while it is loaded. Keep all ammunition away from the work area. Eye protection is required when working on any firearm. Keep the muzzle pointed in a safe direction at all times while working on your firearm! When shooting your gun always wear shooting glasses and hearing protectors!

LEAD EXPOSURE WARNING

Discharging firearms in poorly ventilated areas, cleaning firearms, or handling ammunition may result in exposure to lead and other substances known to the State of California to cause birth defects, reproductive harm, and other serious physical injury. Have adequate ventilation at all times. Wash hands thoroughly after exposure.

MAGAZINE

The AR-22 Combo was designed to function with the Black Dog Machine 10 round or 25 round X Form magazines.

LOADING THE MAGAZINE

To load the magazine, press the rim of the cartridge against the magazine follower at the widest of the section of the steel feed lips until the cartridge enters far enough to be pushed to the rear of the magazine. Continue this process until all 10 or 25 cartridges are loaded into the magazine.

INSTALLING THE BARREL INTO YOUR RECEIVER

Place the Upper Receiver into your Action Block. There are several available in the marketplace. Please follow the instructions from the manufacturer of your action block.

Place the Action Block into your Vise and tighten until snug-but do not over-tighten. Slide the Barrel into the threaded end of the Upper Receiver. Make sure the pin on the Barrel lines up with the slot in the Upper Receiver. Slide Barrel all the way into the Upper Receiver until the pin hits the back of the slot. Apply grease or recommend lubricant to the receiver threads.

Seat the Threads and tighten the barrel nut per the handguard manufacturers recommendation. We recommend:

1. Torque to 35 ft-lbs
2. Loosen
3. Torque to 35 ft-lbs
4. Loosen
5. Torque past 35 ft-lbs until gas holes are in alignment, making sure not to exceed 65 lbs.

Finish install the handguard.

Insert bolt assembly in the upper receiver.

DISASSEMBLY & CLEANING - GENERAL

Starting with an unloaded rifle, switch the rifle to “fire,” cock the hammer, then switch rifle to “safe”, turn the rifle on its right side and push out the two receiver pins holding the upper to the lower receiver.

Point the muzzle down and remove the upper from the lower receiver, with your thumb holding pressure against the bolt assembly to prevent it from sliding out of the upper.

With your hand at the rear of the upper, invert the upper and gently slide out the bolt assembly. Then remove the charging handle.

The bolt assembly can be wiped off with a shop rag and scrubbed with a brush for basic maintenance.

Wipe out the inside of the receiver.

With the upper inverted in a cleaning rack, wipe off the face of the breech, taking care to remove any built-up carbon or copper plating fouling.

To clean the barrel, traditional cleaning methods should be used with this rifle, noting that keeping the chamber clean is important to maintain reliability and function in the AR-22 Combo. The upper should be cleaned from the rear, using a .22 caliber rimfire specific cleaning rod and solvents.

DISASSEMBLY – BOLT ASSEMBLY

With the bolt assembly pointed away from you, gently slide the top recoil spring assembly to the left, while holding the lower bolt and bolt carrier. Do not compress the recoil spring during this process.

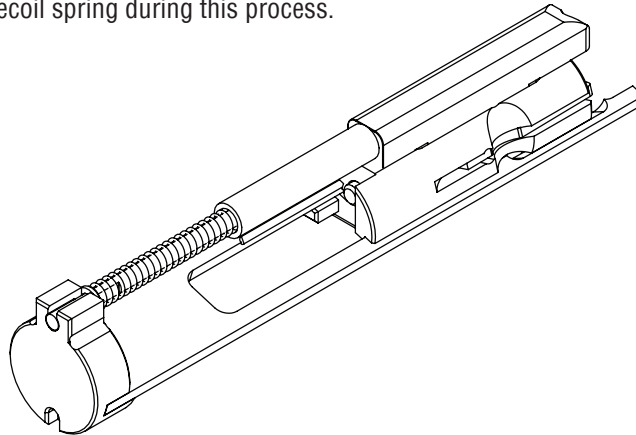

Once the recoil spring assembly is pushed to the left, gently push the bolt out, allowing the steel tabs to clear the bolt. This requires very little force and the bolt should slip into the carrier easily.



3

Once the recoil spring assembly is clear from the bolt, the bolt will slide forward off the carrier.

To remove the firing pin from the bolt, gently tap the firing pin stop out from the bottom of the bolt, while holding pressure on the back of the firing pin.

Remove firing pin and spring, and clean. Brush out the extractor slot and groove, and wipe out the inside of the firing pin hole inside the bolt. A cotton swab is good for this.

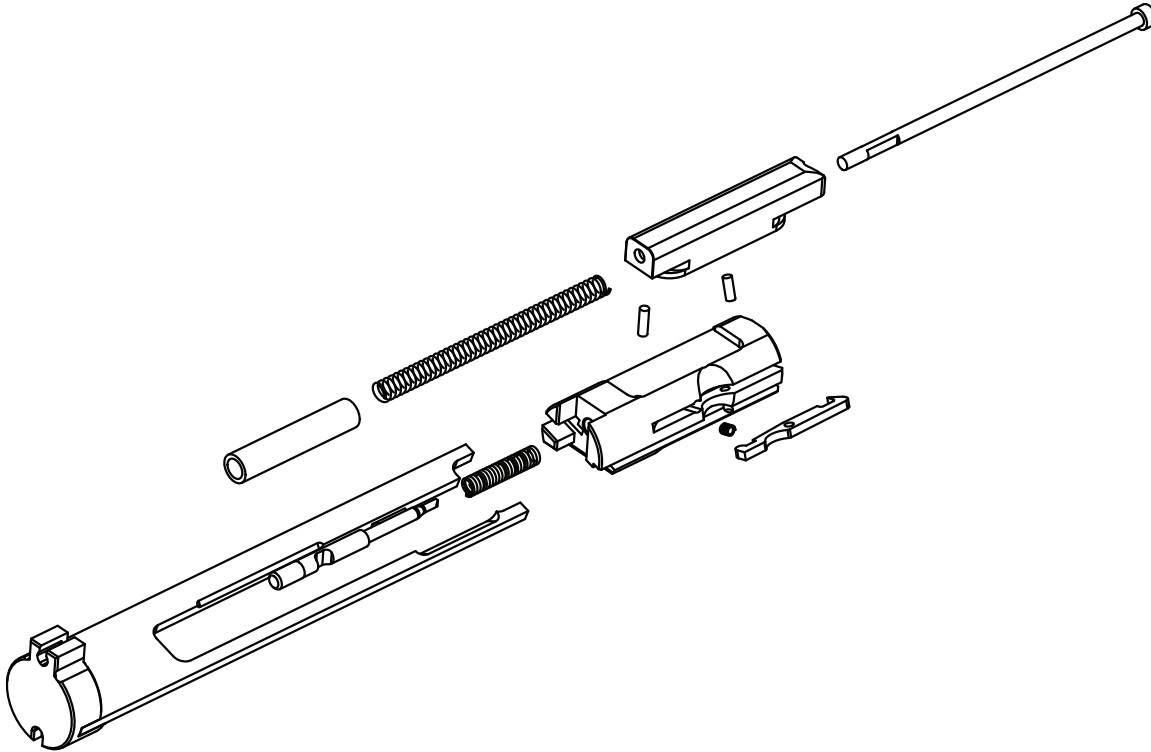

REASSEMBLY

Lightly oil the firing pin and remove any excess oil. Reassemble the conversion in reverse order. Align the firing pin stop notch with the stop-pin hole in the bolt, and reinsert the stop pin from the top of the bolt, pushing it down into place.

Note: Over oiling the bolt components will cause premature carbon build up, which may decrease performance or increase the frequency in which the assembly must be cleaned.

Push the front part of the recoil assembly to the left, and slide the bolt onto the carrier. Once the bolt lines up with the recoil spring assembly, slide the recoil assembly to the right and connect it to the bolt.

Reinstall the charging handle and then slide the bolt assembly into the upper receiver.

With the bolt assembly pushed all the way forward, set the AR-22 upper on the lower receiver and push the retaining pins back in place.

NOTES ON AMMUNITION SELECTION & CLEANING FREQUENCY

The AR-22 Combo is designed to work best with most high-velocity rimfire ammunition. The units are tested at the factory with CCI Blazer.

Some low-grade bulk ammunition does not perform reliably in the AR-22, and like any semi automatic rimfire firearm, testing out different ammunition types is important.

Keeping your AR-22 clean is essential for proper functioning and service life. Through our experience with the AR-22, we have found some general round-count based cleaning cycles that will help keep the AR-22 running well.

For the Barrel and Bolt Assembly: Clean every 300 to 500 rounds.