

.22 LONG RIFLE CONVERSION FOR GLOCK® PISTOLS

**MANDATORY USE OF FACTORY MANUAL WARNING.**

**READ THE INSTRUCTIONS AND WARNINGS BEFORE USING THIS PRODUCT.**

This manual in no way replaces or supersedes information or instructions from your gun manufacturer. In the event of a difference or conflict between your manufacturer's information and information contained herein, the official manufacturer's instructions shall always take precedence. **Do no alter this conversion in any way.**

- **LOADED WEAPON WARNING**
- **ALWAYS MAKE SURE YOUR GUN IS UNLOADED BEFORE ANY WORK IS STARTED.** IT IS POSSIBLE TO FIRE THIS WEAPON WITHOUT A MAGAZINE. ALWAYS CHECK THE CHAMBER TO VERIFY THAT IT IS EMPTY BEFORE ANY FIELD-STRIPPING, CLEANING, OR ANY OTHER WORK IS PERFORMED ON THE WEAPON. KEEP ALL AMMUNITION AWAY FROM THE WORK AREA.
- **NEVER CLEAN, LUBRICATE, DISASSEMBLE, REASSEMBLE OR WORK ON ANY FIREARM WHILE IT IS LOADED.**
- **MUZZLE SAFETY WARNING: KEEP THE PISTOL MUZZLE POINTED IN A SAFE DIRECTION AT ALL TIMES WHILE WORKING ON YOUR FIREARM.**

**TSG-22® 19/23 & 17/22 RIMFIRE CONVERSION**

The TSG-22 quickly and easily converts Generations 1 through 4 of the Glock models 19/23\* and 17/22\* into an accurate .22LR pistol. This conversion maintains a similar weight and feel to your factory Glock pistol, allowing for cost effective shooting and training. Each conversion undergoes a nitride surface treatment to increase wear resistance, inhibit corrosion, and reduce friction. Our TSG-22® conversion features factory Glock® sights and includes one Tactical Solutions 10-round polymer magazine. Offered in our standard muzzle configuration or our threaded [1/2" X 28] end configuration, for the addition of a suppressor.

\*17/22 Conversions fit the following Glock Models, Generation 1 - 4: 17, 22, 31, 34, 35, and 37

\*19/23 Conversions fit the following Glock Models, Generation 1 - 4: 19, 23, 32, and 38

**INSTALLING THE TSG-22 CONVERSION:**

- Please follow the Glock® owner's manual for removal of the Glock slide. If you do not have a Glock owner's manual please contact Glock Inc. for a copy.
- Once the Glock slide has been removed the TSG-22 can be installed using the reassembly procedure from the Glock manual.
- **This Conversion is designed to fit on factory Glock frames only.**

**CLEANING THE TSG-22:**

- We recommend cleaning and lubricating your TSG-22 conversion:
- When new, before the first time the conversion is fired.
- After each time it is fired prior to storing the conversion.
- When required due to fouling from firing or adverse conditions.
- Remove the TSG-22 in a similar fashion as the Glock slide was removed.
- Remove the recoil spring assembly from the conversion by pushing the assembly forward and lifting up on the rear of the assembly. Note: The recoil spring assembly is not designed to be disassembled.
- Slide the guide rod retainer (buffer) toward the rear of the slide and remove.
- Position the barrel so that the notch on the slide for the ejector screw and the ejector screw on the barrel line up. Note: The ejector is fixed to the barrel please do not attempt to remove.
- Lift up on the barrel lug and slide out barrel from the slide.

**REASSEMBLY CONTINUED:**

- Making sure that the firing housing screws are free of any fouling, oils, or solvents apply a drop of medium strength thread locker to each of the screws and replace the screws into the housing. Note: The rear retaining screw is longer than the forward screw and these screws need to be located into the correct location when the conversion is reassembled. Do not tighten screws until both screws have been started into their proper hole location.
- Check to make sure the firing pin safety is operating correctly by pulling back on the firing pin leg and gently releasing. Once the leg has been released the firing pin safety can be depressed and the firing pin should move forward. If this does not happen please remove firing pin housing and check the firing pin safety spring and safety. Do not install on your Glock® frame without making sure the firing pin safety is functioning correctly.
- Insert the muzzle end of the barrel into the slide and position the barrel so that the notch on the slide for the ejector screw and the ejector screw on the barrel line up.
- Place the barrel into position.
- Move the barrel back and forth in the slide making sure the barrel and firing pin housing are in proper alignment.
- Apply lubrication on TSG-22 as directed in lubrication section.
- Insert the guide rod retainer (buffer) into the notch towards the end of the slide with the end that has the smaller hole facing towards the muzzle end of the slide. Insert the recoil spring assembly into the guide rod retainer (buffer) then into the cutout on the barrel. Install on your Glock frame using the reassembly procedure from the Glock factory manual.

**CLEANING THE TSG-22 CONTINUED:**

- Using the supplied 1/16" Allen wrench remove the two firing pin housing retaining screws. Note: The rear retaining screw is longer than the forward screw and these screws need to be located into the correct location when the conversion is reassembled.
- Clean the barrel from the chamber end. Make sure to remove the fouling from the face of the barrel and the extractor notch. Standard barrel solvents maybe used however the barrel and chamber must wiped dry with a clean cloth prior to reassembly.
- The slide should now be cleaned removing any fouling on the slide. Make sure to remove all debris from the slide rail cuts. Any solvents used during the cleaning process must be removed prior to reassembly of the slide.

**REASSEMBLY:**

- Insert the firing pin assembly into the firing pin housing.
- Make sure that firing pin safety and spring are properly inserted into the firing pin housing.
- To insert the firing pin housing into the slide the firing pin assembly must be compressed using the inside of the back wall of the slide as the housing is inserted. The firing pin housing must be inserted evenly into the slide for proper alignment. Note: As the housing is inserted into the slide the lug on the firing should be pressed forward to keep the firing pin safety in proper position.

**LUBRICATION:**

- Apply one drop of lubrication to each of the areas shown in the diagram to properly lubricate the TSG-22 conversion.
- Do not over lubricate your TSG-22 conversion. Over lubrication or use of grease or heavy oils can cause function issues and cause an excess of fouling with the TSG-22 conversion.

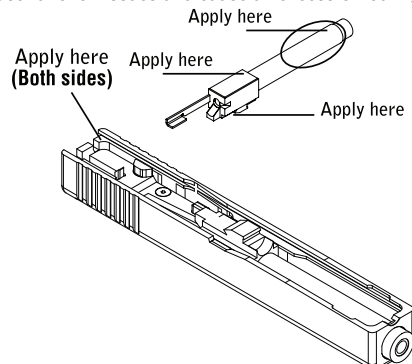

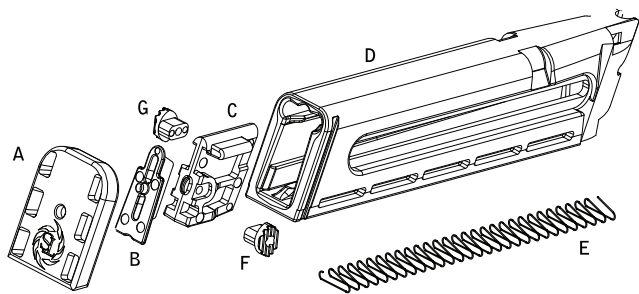

**MAGAZINE PARTS LIST:**

- A Base Plate
- B Detent Plate
- C Follower
- D Body
- E Spring
- F Follower Pulldown Tab [Left]
- G Follower Pulldown Tab [Right]

**CONVERSION PARTS LIST:**

- 1 Slide
- 2 Barrel
- 3 Firing Pin Housing
- 4 Firing Pin
- 5 Firing Pin Sleeve
- 6 Firing Pin Spring
- 7 Firing Pin Spring Cups
- 8 Firing Pin Housing Screw [Rear]
- 9 Firing Pin Housing Screw [Front]
- 10 Firing Pin Safety and Firing Pin Safety Spring
- 11 Recoil Spring Assembly
- 12 Buffer

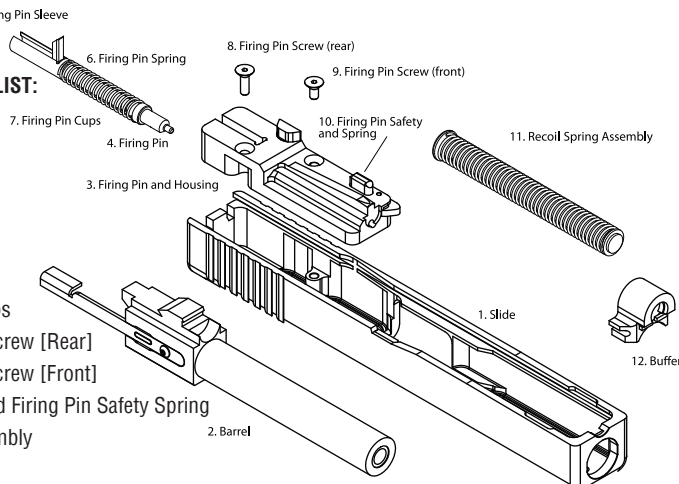

**MAGAZINE DISASSEMBLY AND CLEANING :**

- We recommend frequently cleaning of the magazine for best functionality with the TSG-22 conversion.
- Caution: The magazine spring and detent plate or under spring tension and can cause injury if not controlled during disassembly. Wear safety glasses during the disassembly to help avoid injury. Make sure to control the detent plate and spring during disassembly.
- Using a punch, press in on the detent plate through the hole in the magazine base plate until the detent plate clears the base plate. Carefully slide the base plate to the side while placing thumb on the detent plate to control the plate and spring.
- Slowly remove the spring and detent plate.
- Use a 5/64" Allen wrench to remove the screw for the pull down tabs. Once the screw is removed the tabs should be removed and the follower can slide out of the bottom of the magazine.
- Dish soap, warm water, and a small bristle brush is all that is required to clean the magazine bodies and follower. Do not use any solvents or oils on the magazine parts.
- Thoroughly dry the magazine before reassembling the magazine
- Use the reverse procedure to reassemble the magazine. When tightening the pull down tab screw on the follower do not over tighten or the tabs will bind on the side of the magazine and cause function / feeding issues on the TSG-22. Verify the follower moves freely in the magazine before continuing with reassembly.

**TSG-22 AMMUNITION RECOMMENDATIONS :**

Thank you for purchasing the TSG-22 17/22 model conversion for Glock® model 17 and 22 pistols. For best results with your TSG-22 .22LR conversion use high velocity ammunition with a 40 grain round nose bullet. We do not recommend the use of hypervelocity ammunition.

**RECOMMENDED AMMUNITION:**

- CCI® Blazers
- CCI® Mini-Mag HV
- High Velocity 40 grain Round Nose Ammunition

**STATE BY STATE FIREARM WARNINGS**

**CALIFORNIA:** "Children are attracted to and can operate firearms that can cause severe injuries or death. Prevent child access by always keeping guns locked away and unloaded when not in use. If you keep a loaded firearm where a child obtains and improperly uses it, you can be fined and sent to prison!" **ADVERTENCIA** "A los niños los atraen las armas de fuego y las pueden hacer funcionar. Ellos pueden causarse lesiones graves y la muerte. Evite que los niños tengan acceso a las armas de fuego guardándolas siempre con no las esté utilizando. Si usted tiene un arma de fuego cargada en un lugar en que un niño tiene acceso a ella y la usa indebidamente, le pueden dar una multa o enviarse a la cárcel." **CONNECTICUT:** "Unlawful storage of a loaded firearm may result in imprisonment or fine." **FLORIDA:** It is unlawful, and punishable by imprisonment and fine, for any adult to store or leave a firearms in any place within the reach or easy access of a minor under 18 years of age or to knowingly sell or otherwise transfer ownership or possession of a firearm to a minor or a person of unsound mind." **MAINE:** Endangering the welfare of a child is a crime. If you leave a firearm and ammunition within easy access of a child, you may be subject to a fine, imprisonment or both. Keep firearms and ammunition separate. Keep firearms and ammunition locked up. Use trigger locks!" **MARYLAND:** "WARNING: Children can operate firearms which can cause death or serious injury. It is a CRIME to store or leave a loaded firearm in any location where an individual knew or should have known that an unsupervised minor would gain access to the firearm. Store your firearms responsibly!" **MASSACHUSETTS:** "WARNING FROM THE MASSACHUSETTS ATTORNEY GENERAL: This Handgun is not equipped with a device that fully blocks use by unauthorized users. More than 200,000 firearms like this one are stolen from their owners every year in the United States. In addition, there are more than a thousand suicides each year by younger children and teenagers who get access to firearms. Hundreds more die from accidental discharge. It is likely that many more children sustain serious wounds, or inflict such wounds accidentally on others. In order to limit the chance of such misuse, it is imperative that you keep this weapon locked in a secure place and take other steps necessary to limit the possibility of theft or accident. Failure to take reasonable preventive steps may result in innocent lives being lost, and in some circumstances may result in your liability for these deaths." "It is unlawful to store or keep a firearm, rifle, shotgun or machine gun in any place unless that weapon is equipped with a tamper-resistant safety device or is stored or kept in a securely locked container!" **NEW JERSEY:** "It is a criminal offense to leave a loaded firearm within easy access of a minor." **NORTH CAROLINA:** "It is unlawful to store or leave a firearm that can be discharged in a manner that a reasonable person should know is accessible to a minor." **TEXAS:** "It is unlawful to store, transport, or abandon an unsecured firearm in a place where children are likely to be and can obtain access to the firearm." **WISCONSIN** "If you leave a loaded firearm within the reach or easy access of a child you may be fined or imprisoned or both if the child improperly discharges, possesses, or exhibits the firearm." Please check with your licensed retailer or state police for additional warnings which may be required by local law or regulation. Such regulations change constantly, and local authorities are in the best position to advise you on such legal matters



(208)-333-9901 / (866)-333-9901

2772 SOUTH VICTORY VIEW WAY

BOISE, ID 83709

TACTICALSOL.COM