



X-RING VR TSS & X-RING VR TAKEDOWN TSS



Thank you for purchasing your new Tactical Solutions rifle.

THE FOLLOWING INSTRUCTIONS ARE DESIGNED TO ASSIST YOU WITH THE OPERATION AND MAINTENANCE OF YOUR NEW X-RING RIFLE.

LOADED FIREARM WARNING

ALWAYS MAKE SURE YOUR GUN IS UNLOADED BEFORE ANY WORK IS STARTED. MAKE CERTAIN YOUR RIFLE IS POINTED IN A SAFE DIRECTION AT ALL TIMES.

NEVER CLEAN, LUBRICATE, DISASSEMBLE, REASSEMBLE OR WORK ON ANY FIREARM WHILE IT IS LOADED. KEEP ALL AMUNITION AWAY FROM THE WORK AREA.

EYE AND EAR PROTECTION REQUIRED

WHEN SHOOTING YOUR GUN ALWAYS WEAR SHOOTING GLASSES AND HEARING PROTECTORS!

LEAD EXPOSURE WARNING

DISCHARGING FIREARMS IN POORLY VENTILATED AREAS, CLEANING FIREARMS, OR HANDLING AMMUNITION MAY RESULT IN EXPOSURE TO LEAD AND OTHER SUBSTANCES KNOWN TO THE STATE OF CALIFORNIA TO CAUSE BIRTH DEFECTS, REPRODUCTIVE HARM, AND OTHER SERIOUS PHYSICAL INJURY. MAKE CERTAIN THAT YOU HAVE ADEQUATE VENTILATION AT ALL TIMES. WASH HANDS THOROUGHLY AFTER EXPOSURE.

HANDLING WARNING

IF DROPPED OR STRUCK WITH THE SAFETY "OFF", THE RIFLE MAY FIRE. KEEP CHAMBER EMPTY UNLESS ACTIVELY FIRING YOUR RIFLE! KEEP SAFETY "ON" UNTIL YOU ARE READY TO FIRE!

AMMUNITION WARNING

DEATH, SERIOUS INJURY, AND DAMAGE CAN RESULT FROM THE USE OF WRONG AMMUNITION, BORE OBSTRUCTIONS, POWDER OVERLOADS, OR INCORRECT CARTRIDGE COMPONENTS. 22LR CASES ARE VERY THIN AND MAY SPLIT WHEN FIRED. USE ONLY NEW, .22LR FACTORY AMMUNITION!

FIREARM SAFETY RULES

THE FOLLOWING RULES MUST BE USED BY GUN USERS AT ALL TIMES. SAFE GUN HANDLING IS ABSOLUTELY ESSENTIAL TO YOUR SAFETY, THE SAFETY OF OTHERS, AND THE CONTINUATION OF GUN OWNERSHIP AND SPORT SHOOTING!

1. LEARN THE MECHANICS AND HANDLING USES OF THE FIREARM YOU ARE USING.
2. ALWAYS KEEP THE MUZZLE POINTED IN A SAFE DIRECTION.
3. FIREARMS SHOULD BE UNLOADED WHEN NOT IN USE AND THE SAFETY SET TO THE "ON" OR SAFE POSITION.
4. BE SURE THE BARREL IS CLEAR OF ANY OBJECTS, MUD, SNOW OR EXCESS GREASE OR LUBRICANT.
5. BE SURE OF YOUR TARGET AND WHAT IS BEYOND YOUR TARGET BEFORE SHOOTING.
6. WEAR SHOOTING GLASSES AND HEARING PROTECTION WHEN SHOOTING OR WHEN AROUND OTHER PEOPLE THAT ARE SHOOTING.
7. NEVER CLIMB A TREE OR FENCE WHEN HOLDING A FIREARM.
8. DO NOT SHOOT AT A HARD SURFACE OR AT WATER.
9. NEVER TRANSPORT A LOADED FIREARM.
10. DO NOT CONSUME ALCOHOL WHEN SHOOTING.

STATE BY STATE FIREARM WARNINGS

CALIFORNIA:



WARNING:

“Firearms must be handled responsibly and securely stored to prevent access by children and other unauthorized users. California has strict laws pertaining to firearms, and you may be fined or imprisoned if you fail to comply with them. Visit the Web site of the California Attorney General at <https://oag.ca.gov/firearms> for information on firearm laws applicable to you and how you can comply. Prevent child access by always keeping guns locked away and unloaded when not in use. If you keep a loaded firearm where a child obtains and improperly uses it, you may be fined or sent to prison. If you or someone you know is contemplating suicide, please call the national suicide prevention lifeline at 1-800-273-TALK (8255).” **



ADVERTENCIA:

“Las armas de fuego deben manipularse de manera responsable y segura para evitar el acceso de niños y otros usuarios no autorizados. California tiene leyes estrictas relacionadas con armas de fuego, y usted puede ser multado o encarcelado si no las cumple. Visite el sitio web del Procurador General de California en <https://oag.ca.gov/firearms> para obtener información sobre las leyes de armas de fuego que le son aplicables y cómo puede cumplirlas. A los niños los atraen las armas de fuego y las pueden hacer funcionar. Ellos pueden causarse lesiones graves y la muerte. Evite que los niños tengan acceso a las armas de fuego guardándolas siempre con llave y descargadas cuando no las esté utilizando. Si usted tiene un arma de fuego cargada en un lugar en que un niño tiene acceso a ella y la usa indebidamente, le pueden dar una multa o enviarlo a la cárcel. Si usted o alguien que conoce está pensando en suicidarse, llame a la línea nacional de prevención del suicidio al 1-800-273-TALK (8255).” **

CONNECTICUT:

“UNLAWFUL STORAGE OF A LOADED FIREARM MAY RESULT IN IMPRISONMENT OR FINE.” **

FLORIDA:

“IT IS UNLAWFUL, AND PUNISHABLE BY IMPRISONMENT AND FINE, FOR ANY ADULT TO STORE OR LEAVE A FIREARM IN ANY PLACE WITHIN THE REACH OR EASY ACCESS OF A MINOR UNDER 18 YEARS OF AGE OR TO KNOWINGLY SELL OR OTHERWISE TRANSFER OWNERSHIP OR POSSESSION OF A FIREARM TO A MINOR OR A PERSON OF UNSOUND MIND.” **

MAINE:

“ENDANGERING THE WELFARE OF A CHILD IS A CRIME. IF YOU LEAVE A FIREARM AND AMMUNITION WITHIN EASY ACCESS OF A CHILD, YOU MAY BE SUBJECT TO FINE, IMPRISONMENT OR BOTH. KEEP FIREARMS AND AMMUNITION SEPARATE. KEEP FIREARMS AND AMMUNITION LOCKED UP. USE TRIGGER LOCKS.” **

MARYLAND:

“WARNING: Children can operate firearms which may cause death or serious injury. It is a crime to store or leave a loaded firearm in any location where an individual knew or should have known that an unsupervised minor would gain access to the firearm. Store your firearm responsibly!” **

MASSACHUSETTS:

“IT IS UNLAWFUL TO STORE OR KEEP A FIREARM, RIFLE, SHOTGUN OR MACHINE GUN IN ANY PLACE UNLESS THAT WEAPON IS EQUIPPED WITH A TAMPER-RESISTANT SAFETY DEVICE OR IS STORED OR KEPT IN A SECURELY LOCKED CONTAINER.” **

NEW JERSEY:

“IT IS A CRIMINAL OFFENSE TO LEAVE A LOADED FIREARM WITHIN EASY ACCESS OF A MINOR.” **

NEW YORK:

“THE USE OF A LOCKING DEVICE OR SAFETY LOCK IS ONLY ONE ASPECT OF RESPONSIBLE FIREARM STORAGE. FOR INCREASED SAFETY, FIREARMS SHOULD BE STORED UNLOADED AND LOCKED IN A LOCATION THAT IS BOTH SEPARATE FROM THEIR AMMUNITION AND INACCESSIBLE TO CHILDREN AND UNAUTHORIZED PERSONS.” **

NORTH CAROLINA:

“IT IS UNLAWFUL TO STORE OR LEAVE A FIREARM THAT CAN BE DISCHARGED IN A MANNER THAT A REASONABLE PERSON SHOULD KNOW IS ACCESSIBLE TO A MINOR.” **

TEXAS:

“IT IS UNLAWFUL TO STORE, TRANSPORT, OR ABANDON AN UNSECURED FIREARM IN A PLACE WHERE CHILDREN ARE LIKELY TO BE AND CAN OBTAIN ACCESS TO THE FIREARM.” **

WISCONSIN:

“IF YOU LEAVE A LOADED FIREARM WITHIN THE REACH OR EASY ACCESS OF A CHILD YOU MAY BE FINED OR IMPRISONED OR BOTH IF THE CHILD IMPROPERLY DISCHARGES, POSSESSES, OR EXHIBITS THE FIREARM.” **

****State Firearm Warnings are subject to change at any time. These state by state warnings are current as of March, 2022.**

USE OF X-RING VR TSS:

The X-RING VR TSS Rifles are designed to perform best with .22LR subsonic ammunition and to be used “dry” without any fluids added to the suppressor / baffle assembly. The addition of any fluids to the baffle system prior to firing may damage the baffle components. IT IS RECOMMENDED THAT YOU CLEAN THE TSS UPPER AND BAFFLE ASSEMBLY EVERY 250 ROUNDS.

OPERATION

The X-Ring rifle will fire if there is a cartridge in the chamber and the trigger is pulled, whether or not there is a magazine in place! Removing the magazine does not unload the rifle. Never assume the rifle is unloaded. With the rifle pointed in a safe direction, visually inspect the chamber and the magazine each time the rifle is handled to be certain there are no live cartridges in the chamber or magazine.

SAFETY

The X-Ring rifle has a cross-button safety which is located in the forward portion of the trigger guard. The safety is engaged when it protrudes fully from the right side of the trigger guard assembly. The safety should always be in the engaged position except when the shooter is actually firing the rifle. The safety is in the fire position when it protrudes from the left side of the trigger guard assembly. When the safety is in the fire position the red band is visible on the safety button. The rifle will fire whenever the safety is in the fire position and the trigger is pulled.

BOLT LOCK [RUGER® TRIGGER GROUP] [FIGURE A] [Oval shaped trigger guard, Polymer housing and trigger]

The bolt lock is located in the forward section of the trigger guard. The bolt lock is the manually operated means of retaining the bolt in the open position. When the bolt is locked open, the rifle is in a safe condition for inspection and cleaning. To lock the bolt open, first point the muzzle in a safe direction: pull back the bolt handle to its furthest rear position and, while continuing to hold the charging handle, press in on the lower section of the bolt lock. Release pressure on the charging handle and it will move forward just slightly then it will be locked in its open position. To release the bolt: Pull the bolt handle to the rearward position and then press in on the upper section of the bolt lock. Release the bolt and it will move fully forward.

BOLT LOCK [XRT™ TRIGGER GROUP] [FIGURE B] [Contoured Trigger Guard, Aluminum housing and trigger]

The bolt lock is located in the forward section of the trigger guard. The bolt lock is the manually operated means of retaining the bolt in the open position. When the bolt is locked open, the rifle is in a safe condition for inspection and cleaning. To lock the bolt open, first point the muzzle in a safe direction: pull back the bolt handle to its furthest rear position and, while continuing to hold the charging handle, press up on the bolt lock. Release pressure on the charging handle and it will move forward just slightly then it will be locked in its open position. To release the bolt: Pull the bolt handle to the rearward position and then release the bolt and it will move fully forward.

Figure A

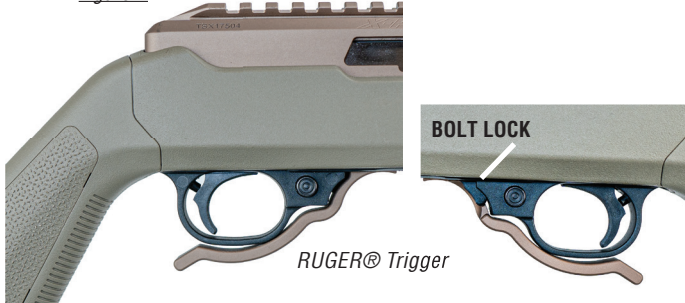
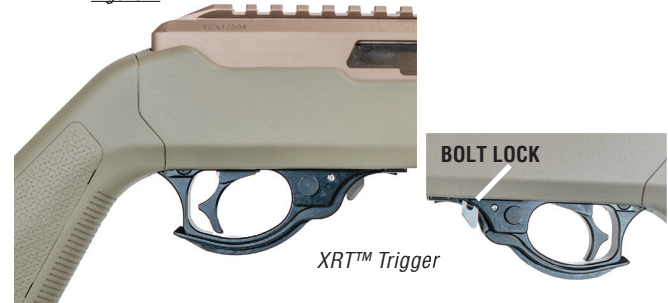

Figure B



LOADING THE MAGAZINE The X-RING rifles were designed to function with the Ruger® factory 10 round 22 long rifle magazine (BX-1).

To load the magazine, press the rim of the cartridge against the magazine follower at the widest section of the steel feed lips until the cartridge enters far enough to be pushed to the rear of the magazine. Continue this process until all 10 cartridges are loaded into the magazine.

LOADING THE RIFLE [Make certain that your rifle's safety is set to the “On” position]

1. Make sure the muzzle is pointed in a safe direction and lock the bolt in the rear position (follow previous bolt lock instructions).
2. Load magazine (refer to magazine loading instructions).
3. With the safety on, insert the loaded magazine into the receiver with the bullet facing towards the muzzle of the rifle. The magazine will not insert into the receiver if the magazine is reversed.
4. To load a cartridge into the chamber, release the bolt from the locked position, allowing the bolt to travel fully forward (see bolt lock instructions). *Do not force the bolt to close, if a cartridge does not chamber properly, lock the bolt into the open position, remove the magazine, and clear the stuck cartridge.*
5. Once the bolt is in battery and the cartridge is fully seated in the chamber, the rifle is now ready to fire.
6. The safety should remain in the *on* position until ready to fire.
7. Firing the rifle will automatically load another cartridge into the chamber.
8. Every time the trigger is pulled, if there is a cartridge in the chamber the rifle will fire.
9. The safety must be engaged when firing has finished and should remain there / ON until ready to engage the intended target.
10. The rifle will fire if the magazine has been removed and a round is still in the chamber.
11. The bolt does not automatically remain open after the last round has been shot. Make sure the chamber is clear after the last shot has been fired.

UNLOADING YOUR RIFLE [Make certain that your rifle's safety is set to the “On” position]

1. Keep the muzzle in a safe direction.
2. Keep your finger off the trigger.
3. When firing has been completed, remove the magazine and lock the bolt in the rear position.
4. Visually inspect the chamber to verify that the chamber is empty.

DISASSEMBLY OF RIFLES

Safety Glasses *As a safety note, the recoil springs will be under considerable tension when removing the bolt from the receiver. Safety glasses are necessary to protect your eyes during this process. *

1. Starting with an unloaded rifle and pointing the muzzle in a safe direction, turn the rifle upside down exposing the action screw [Figure C], and remove. Push the trigger group's safety to the middle position, allowing it to clear the stock. Turn the rifle back upright, pivot the barrel slightly upwards, and raise the barreled action out from the stock.
2. Clamp the barreled receiver in either a padded vice, or hold it down on the V-Block and gently tap out the two receiver pins with a 5/32" punch and remove the trigger group. Be careful to tap the pins out gently. DO NOT DRY FIRE THE TRIGGER OUTSIDE OF THE RIFLE.
3. With a 9/64" sized Hex / Allen wrench, unscrew the charging handle from the bolt and remove.
4. Invert the receiver and gently tap down on the rear of the two recoil spring guide rods, fully seating them into the receiver. Then tap out the bolt buffer from the side of the action. To remove the stainless steel plug in the rear portion of the receiver, push it from the outside of the receiver to the inside of the receiver.
5. Notice the two small holes on the underside of the bolt. These are designed to allow a pair of paperclips or 1/16" sized punches to be inserted once the bolt is pushed back, locking the recoil guide rods in place. This is necessary to remove the bolt. It's easier to use two small paperclips because they will stay in place. To start, push the bolt completely to the rear of the action and hold in place. Slide a straightened end of a paperclip into each hole, approximately 3/4" deep, securing the guide rods in place.
6. Turn the barreled receiver right side up and carefully tap the top of the receiver. This should allow the rear of the bolt to drop down and out of the receiver. Keep in mind that the bolt needs to pivot downward to drop out.
7. With the bolt removed, the barreled receiver and bolt are now ready for cleaning.

CLEANING OF RIFLE BARREL / RECEIVER

1. With the rifle disassembled, start by wiping down the inside of the receiver and breech-face of the barrel with a shop rag. Once the receiver is clean, wipe down the bolt, recoil guide rods, and springs. Then brush off the bolt face, making sure you get under the extractor.
2. When the baffle assembly is removed from the barrel body, you can either use a traditional cleaning rod and patch, or pull-through cleaning system to remove fouling from the chamber and barrel. With all rimfire rifles, it's important to clean any fouling from the chamber.
3. To clean the bolt, cover the rear of the bolt with a shop rag and pointed in a safe direction, carefully remove the paperclips one at a time and gently remove the recoil guide rods and springs. Remember that the springs are under pressure and will shoot out if not restrained.
4. While holding pressure on the rear of the firing pin, tap out the firing pin retaining pin with 3/32" size punch from the underside of the bolt. Remove the firing pin and rebound spring. Firing pin is under spring tension.
5. Clean out the guide rod holes and the firing pin hole at the rear of the bolt, and brush off the bolt face.

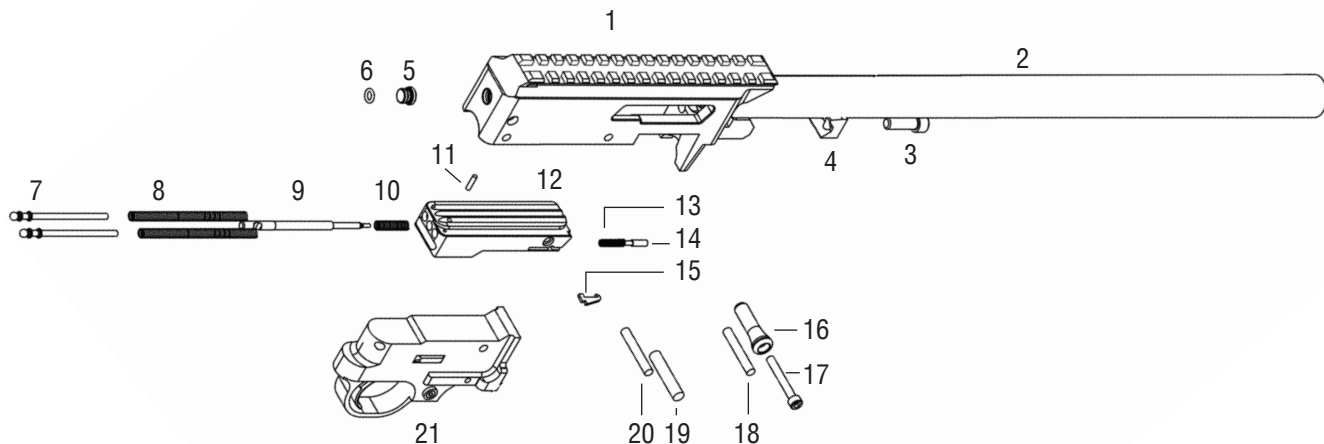

PARTS LIST

- | | |
|-------------------------|------------------------------|
| 1. RECEIVER | 11. FIRING PIN STOP PIN |
| 2. BARREL | 12. BOLT |
| 3. V-BLOCK SCREWS | 13. EXTRACTOR PLUNGER SPRING |
| 4. V-BLOCK | 14. EXTRACTOR PLUNGER |
| 5. CLEANING PLUG | 15. EXTRACTOR |
| 6. CLEANING PLUG O-RING | 16. CHARGING HANDLE |
| 7. RECOIL GUIDE RODS | 17. CHARGING HANDLE SCREW |
| 8. RECOIL SPRINGS | 18. RECEIVER PIN |
| 9. FIRING PIN | 19. RECOIL BUFFER |
| 10. FIRING PIN SPRING | 20. RECEIVER PIN |
| | 21. TRIGGER GROUP |

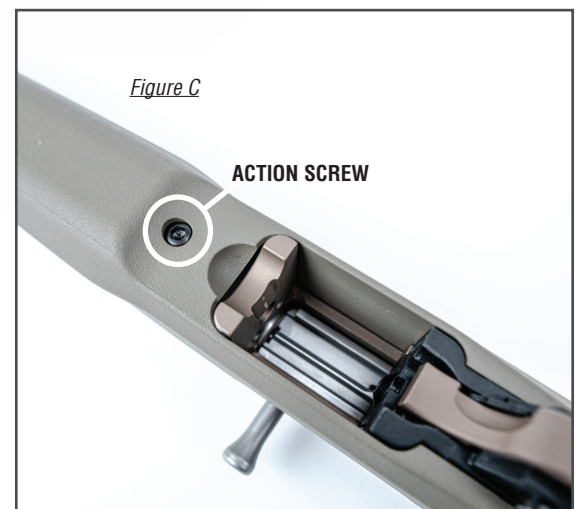

TRIGGER GROUP CLEANING Ruger® BX Trigger [FIGURE A] For Ruger® Trigger group cleaning follow these steps.

1. Using a gun cleaning solvent on a clean patch wipe away any noticeable fouling from the trigger group housing and components.
2. After cleaning away any fouling, wipe down the trigger group housing and components using a lightly oiled patch.
3. Then wipe the trigger group housing clean, removing any oil, with a cloth.

TRIGGER GROUP CLEANING XRT Trigger [FIGURE B]

The XRT is greased and lubricated at the factory, and the use of strong solvents like brake cleaner will remove the grease and decrease the performance of the trigger. After every 5000 rounds of ammunition, we recommend that the XRT is removed and wiped down. [Use a lint-free cloth for this process]

1. After the XRT trigger is removed from the receiver, wipe down the exterior surface to remove any fouling.
2. Looking down into the trigger group, wipe away any visible fouling.
3. Cover plate removal: It is recommended that you only have one cover plate removed at a time. Remove the two right-hand side cover plate screws and remove the cover plate. [Figure D]. Again, wipe down the surface of any fouling and replace the cover plate and screws. [Figure E]
[Do not over torque the cover plate screws. Hand tight only.]
4. Next remove the left-hand side cover plate and wipe any fouling that has accumulated. Replace the cover plate and screws.

Figure D

COVER PLATE SCREWS



Figure E



Figure F



XRT LUBRICATION

1. Place the safety in the OFF / Fire position. Securely place your thumb over the hammer. While maintaining pressure on the hammer, pull the trigger and carefully and slowly allow the hammer to move forward, exposing the hammer strut shaft and hammer spring. [Do not release the hammer without maintaining pressure.]
2. With the hammer strut and hammer strut spring exposed, apply a high-quality firearms oil by placing one small drop of oil in the middle of the hammer strut shaft and hammer spring. [Do not use grease] [Figure F] above
3. Reset the hammer into the fire position. You will hear an audible click when it is engaged.
4. Return the safety to on or "safe" position.

REASSEMBLY & LUBRICATION

1. Reinstall the firing pin and firing pin spring into the bolt, making sure the firing pin slot is lined up in the same direction as the firing pin stop pin hole.
2. Gently tap in the firing pin stop pin into the bolt from the top of the bolt.
3. Reassemble the bolt by inserting the recoil springs into the bolt, then push one recoil guide rod into place at a time and secure with a paper clip or punch.
4. Place a small drop of high-quality firearm oil on the top and sides of the bolt.
5. To insert the bolt into the receiver, tip the front of the bolt slightly downward into the receiver bolt channel, then slip the rear of the guide rod ends into the slots in the back of the receiver. Slide the bolt down with the nose of the bolt pointed down. After the bolt has been inserted into the receiver remove the paperclip or punches. Insert the cleaning plug back into the rear portion of the receiver and insert the recoil buffer into the buffer hole on the side of the receiver.
6. With the bolt in place, reinstall the trigger group and bolt handle. Slide the safety to the middle position and insert the barreled receiver back into the stock.
7. Install action screw and tighten firmly. [Approximately 15 in-lbs.]
8. Pointing your rifle in a safe direction, check to ensure that your safety functions. If you encounter any problems with the safety function of your rifle, please contact our technical support and do not use.

X-RING VR TAKEDOWN TSS BARREL INSTRUCTIONS

BARREL REMOVAL - with the muzzle pointed in a safe direction

1. Remove the magazine and lock the bolt open. Once the magazine is removed verify the rifle is unloaded by visually inspecting the chamber.
2. Loosen the adjustment ring by turning it clockwise.
3. Push the locking lever forward towards the muzzle then rotate the barrel assembly counterclockwise.
4. You can now pull the barrel assembly out of the receiver.

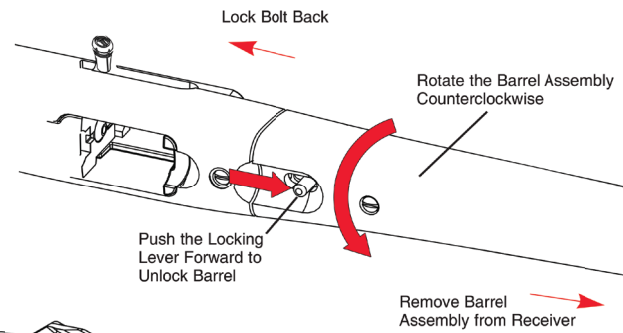

X-RING VR TAKEDOWN TSS BARREL INSTRUCTIONS

BARREL INSTALLATION - with the muzzle pointed in a safe direction

1. Slightly rotate the barrel assembly towards the left side of the rifle and insert the barrel shank into the receiver.
2. Rotate the barrel clockwise until it locks into place.
3. Tighten the adjustment ring by turning it counterclockwise until it is tight.
4. Cycle the bolt manually several times to properly seat the barrel prior to inserting a loaded magazine and firing the rifle.
5. Tighten the adjustment ring by one or two adjustment clicks.
6. Your rifle is now ready to use.

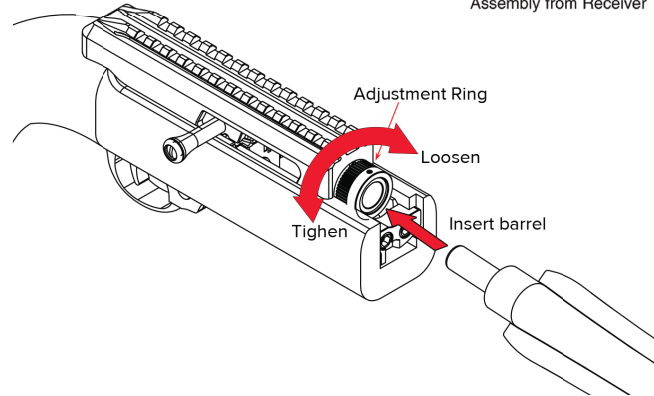

SWITCHING THE REVERSIBLE CHARGING HANDLE [VR RIFLES ONLY]

Use a 9/64" Hex/Allen wrench to unscrew the charging handle screw. Once the charging handle screw has been unscrewed from the rifle's bolt, the charging handle can be removed and switched to the alternate side of the rifle. Reinsert the screw into the charging handle and firmly tighten.

DISASSEMBLY OF SUPPRESSOR / BAFFLE ASSEMBLY

1. **Unload firearm; visually and physically check that the chamber is empty and magazine is removed. - with the muzzle pointed in a safe direction.**

Slide the suppressor wrench over the end cap, aligning the notches on the wrench with the grooves in the end cap. **DISASSEMBLY FIGURE 1**

While holding the barrel firmly in one hand, turn the suppressor wrench counterclockwise to unscrew the end cap.

DISASSEMBLY FIGURE 1



SUPPRESSOR WRENCH

2. Once the end cap is unscrewed and free of the threads, the suppressor assembly can be removed from the X-RING TSS body.

The complete assembly can now be removed by pulling the end cap away from the barrel body. **DISASSEMBLY FIGURE 2**

Note: If an excess of carbon has built up within the suppressor / baffle assembly, it will not easily slide out of the barrel body. If the baffle assembly will not easily slide out

DISASSEMBLY FIGURE 2



END CAP

3. To disassemble the baffle stack the spacer ring must be removed first. You will need the TSS spacer wrench for the removal of the spacer ring. The spacer ring is attached using a **left-hand thread pattern**. To unscrew the spacer ring turn it clockwise using the spacer wrench.

DISASSEMBLY FIGURE 3

DISASSEMBLY FIGURE 3

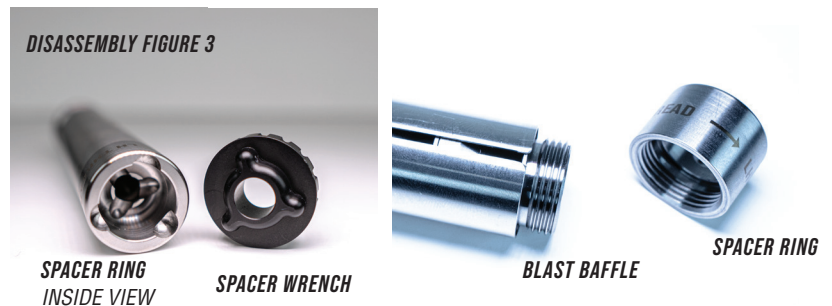

SPACER RING
INSIDE VIEW

SPACER WRENCH

BLAST BAFFLE

SPACER RING

4. Next, grasp the split tube firmly, and with your other hand, pull the end cap and connected baffles out of the split tube until they are free.

DISASSEMBLY FIGURE 4

- The baffles can now be separated for cleaning. See sequential illustration below

DISASSEMBLY FIGURE 4

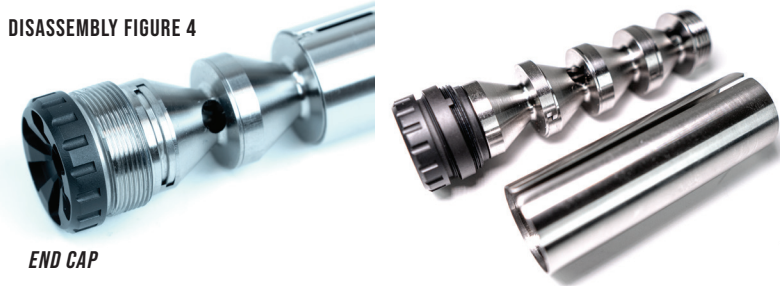

CLEANING OF BAFFLE ASSEMBLY

Tactical Solutions recommends frequent cleaning of your baffle assembly. We recommend cleaning your baffle components every 250 rounds for best performance and ease of disassembly. The baffle assembly and its components are machined to very tight tolerances, so it is extremely important to clean any lead fouling and carbon build up on a regular basis.

Caution: Use protective eyewear and solvent resistant gloves when cleaning your suppressor. Only use cleaning solvents in well ventilated areas and avoid breathing vapors. Dispose of all chemicals in an environmentally safe manner.

We recommend using mineral spirits to soak all suppressor components [blast baffle, baffles, and split tube] for 12-24 hours at a time. Once the disassembled suppressor components have soaked, we then recommend scrubbing the parts with a nylon brush to remove any remaining carbon. Due to the precise tolerances of the baffle stack design, it is critical to completely clean the baffles and spacer ring, removing any fouling which has built up between any of the interlocking surfaces. It is also important to clean the split tube and inside of the pistol's upper receiver tube where the baffle stack is contained. Use a cloth to wipe any residual mineral spirits or debris from the baffle components before assembly. Make sure to clean any residue off of the barrel body, muzzle threads, and end cap threads before inserting the baffle assembly back into the barrel body.

REASSEMBLY OF SUPPRESSOR / BAFFLE ASSEMBLY

- After cleaning the baffle system and its components, start first by placing the end cap face down [with threads facing upward] on your work surface. Shown at right REASSEMBLY FIGURE 1

REASSEMBLY FIGURE 1



- Next, slide the first baffle onto the end cap, aligning the grooves that interlock the two pieces. Shown at right REASSEMBLY FIGURE 2
Note: The location of the baffle vents will alternate from left to right for each additional baffle.

REASSEMBLY FIGURE 2

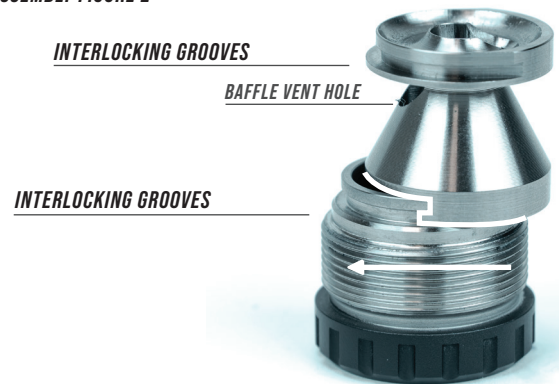

- With the next baffle in hand, slide it into the grooves in the first baffle in the same manner. Note the location of the baffle vents and the direction of the groove alignment. Shown at right REASSEMBLY FIGURE 3
The location of the baffle vents will alternate from left to right for each additional baffle.

REASSEMBLY FIGURE 3

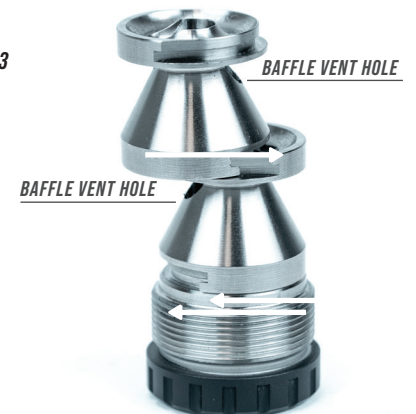

Repeat this process of aligning and stacking baffles until all 4 baffles are interlocked.

REASSEMBLY OF SUPPRESSOR / BAFFLE ASSEMBLY CONTINUED

4. At the right are the assembled baffles stacked prior to the addition of the split tube. **REASSEMBLY FIGURE 4**

Next, you will need to align the *split* in the split tube in a perpendicular orientation to that of the baffle vent hole alignment. Note the hash-marked line along the center of **REASSEMBLY FIGURE 5**, the “split” in the split tube will need to be located there, which will expose a small portion of the baffle stack. **DO NOT align the split tube in a way that exposes the baffle vent holes.** Slide the split tube down the baffle stack, being careful not to separate baffles.

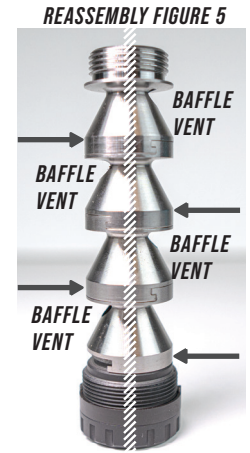

FOR X-RING TAKEDOWN TSS Rifle Only

- 5A. When the split tube is properly aligned and fitted, the blast baffle will be visible with its threads exposed. **REASSEMBLY FIGURE 6**
 Finally, thread on and tighten the spacer ring [with the included spacer wrench] to complete the assembly of the suppressor baffle system. We recommend putting a small amount of anti-seize on the blast baffle’s threads before installing the spacer ring. This will make it easier to remove during service intervals. Using the spacer wrench, tighten the spacer ring by turning to the left. With the spacer ring fully tightened, the split tube should fit securely.

REASSEMBLY FIGURE 7

Slide the Front Sight Ring on to the baffle / suppressor assembly with the lugs on the Front Sight Ring facing toward the suppressor body. Reinsert the baffle / suppressor assembly into the X-RING TAKEDOWN TSS barrel and insert the Front Sight Ring lugs into the notches on the barrel body. Carefully thread the baffle system and barrel together until securely tightened.

The endcap threads should be clean of any residue, solvents, etc., prior to tightening.



FOR X-RING TSS Rifle Only

- 5B. When the split tube is properly aligned and fitted, the blast baffle will be visible with its threads exposed. **REASSEMBLY FIGURE 6**
 Finally, thread on and tighten the spacer ring [with the included spacer wrench] to complete the assembly of the suppressor baffle system. We recommend putting a small amount of anti-seize on the blast baffle’s threads before installing the spacer ring. This will make it easier to remove during service intervals. **REASSEMBLY FIGURE 7** Slide the Muzzle Ring on to the baffle / suppressor assembly with the lugs on the Muzzle Ring facing toward the suppressor body. Reinsert the baffle / suppressor assembly into the X-RING TSS barrel and insert the Muzzle Ring lugs into the notches on the barrel body. Carefully thread the baffle system and barrel together until securely tightened.

The endcap threads should be clean of any residue, solvents, etc., prior to tightening.



TACTICAL SOLUTIONS, INC.

2772 South Victory View Way
 Boise, Idaho 83709



PROUDLY MADE IN BOISE, ID

TACTICALSOL.COM

Ruger® is a Registered Trademark of Sturm, Ruger & Co. Inc.

7/24/23

WARNING:
 Cancer and Reproductive Harm
www.p65warnings.ca.gov/product